

## Rubber Lined Split Clamps

Catalogue Number : 8000101 : Rev. 01 Dated 07-10-2014

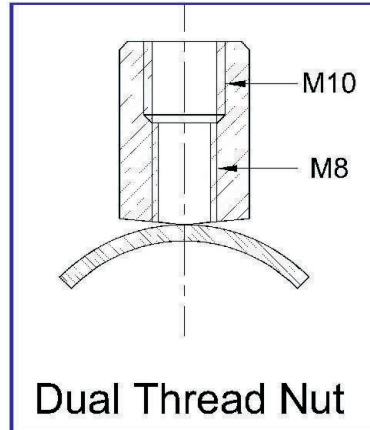
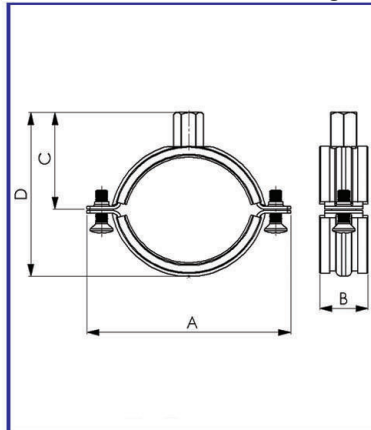

SELECTION TABLE (Table No: B-03-01)

Model No.	Range (mm)	Pipe OD (inch)	Nominal OD (mm)	Fixing Nut	Dimension (mm)				Thick (mm)	Break Load (kgs)	Safe Load (kgs)
					A	B	C	D			
SRLSC018	12-16	3/8" / 1/4"	15	M8 / M8-M10	60	20	26	36	1.5	450	150
SRLSC022	17-23	1/2"	22	M8 / M8-M10	65	20	29	43	1.5	450	150
SRLSC028	24-30	3/4"	28	M8 / M8-M10	70	20	32	50	1.5	450	150
SRLSC035	32-38	1"	35	M8 / M8-M10	85	20	36	56	1.5	450	150
SRLSC040	39-45	1 1/4"	42	M8 / M8-M10	92	20	39	63	1.5	450	150
SRLSC048	45-51	1 1/2"	48	M8 / M8-M10	98	20	42	72	1.5	450	150
SRLSC054	52-58		54	M8 / M8-M10	104	20	45	75	1.5	450	150
SRLSC060	58-64	2"	60	M8 / M8-M10	110	20	48	81	1.5	450	150
SRLSC063	65-71		63	M8 - M10	115	20	51	88	1.5	450	150
SRLSC075	72-81	2 1/2"	75	M8 - M10	125	20	56	96	2	600	200
SRLSC090	82-89	3"	90	M8 - M10	146	20	63	111	2	600	200
SRLSC100	90-98	3 1/2"	100	M8 - M10	156	20	68	121	2	600	200
SRLSC110	99-108		110	M8 - M10	166	20	73	131	2	600	200
SRLSC115	110-116	4"	115	M8 - M10	171	20	78	136	2	600	200
SRLSC125	119-127		125	M10	181	20	81	146	2	600	200
SRLSC133	126-135		133	M10	184	20	85	154	2	600	200
SRLSC140	136-145	5"	140	M10	196	20	88	161	2	600	200
SRLSC150	146-156		150	M10	206	20	93	171	2	600	200
SRLSC168	158-169	6"	168	M10	224	25	102	189	2	600	200
SRLSC170	170-180		175	M10	235	25	106	195	2	600	200
SRLSC194	194-206		190	M10	245	25	110	200	2	600	200
SRLSC200	208-220	8"	200	M10 / M12	256	25	118	221	2.5	900	300
SRLSC220	225-238		220	M10 / M12	276	25	128	241	2.5	900	300
SRLSC250	247-260		250	M10 / M12	306	25	143	271	2.5	900	300

(Table No: B-04-01)

Model No.	Copper (inches)	Steel (Sch 40)		UPVC/PE	ABS
		(inches)	(mm)		
SRLSC018	15, 18	3/8" / 1/4"	16		
SRLSC022	22	1/2"	22	20	DN15 (21.4)
SRLSC028	24, 28	3/4"	28	25	DN20 (26.8)
SRLSC035	35	1"	35	32, 38	DN25 (33.6)
SRLSC040	42	1 1/4"	42	40, 43	DN32 (42.3)
SRLSC048		1 1/2"	48	45	DN40 (48.3)
SRLSC054	54			54	
SRLSC060	64	2"	60	60	DN50 (60.4)
SRLSC063					
SRLSC070	67, 70			70	
SRLSC075	76	2 1/2"	75	75	DN65 (75.4)
SRLSC083	80			83	
SRLSC090		3"	90	90	
SRLSC100	102, 105			102	DN80 (88.9)
SRLSC110	108			110	
SRLSC115		4"	115	115	DN100 (114.3)
SRLSC125	125			125	
SRLSC133				135	
SRLSC140		5"	140	140	DN125 (140.2)
SRLSC150				152	
SRLSC160	159			160	
SRLSC168	167	6"	168		DN150 (168.3)
SRLSC170					
SRLSC194					
SRLSC200	206			200	
SRLSC220		8"	219	220, 225	DN200 (225.0)



### Rubber Lined Split Clamps

#### 1. Compliance:

- Federal Specification AS-A-1192 (Type 1)
- MSS-SP58 (Type 1)
- MSS-SP69
- WW-H-171E (Type 1)
- EG-ASTMB 633 SC3, BS 1706 FE / ZN 12

2. **Material** : Mild Steel elctrogalvanised.

3. **Application** : Ceiling suspension or vertical wall mounting of piping.

#### 4. Features :

- High quality Rubber lining for suppression of sound and vibration.
- Both clamps are ribbed for providing additional strength
- Lips are provided with additional thread lengths by means of extended collared tap holes.
- For pipe size, OD 100 mm and above, welded side nuts have been provided.
- Suspension nuts have twin threads, M8, M10 for flexibility of installation.
- Side bolts have slotted cross head for ease of tightening.

#### 5. Selection / Ordering :

- Pipe OD / pipe size plus insulation thickness.
- Indicate if Starline Rubber Inserts are proposed to be used. (for automatic selection of clamp).
- Hot Dip Galvanised Finish (Suffix "HDG")
- EPDM Lined (Suffix "R")
- Epoxy Powder Coated Finish (Suffix "P")
- Stainless Steel Construction (Suffix "SS")

### *Note:*

- Due to policy of continual improvement, the specifications are subject to change without prior notice
- Measurements are subject to 5% tolerance
- To achieve good sound suppression, do not overload fitting

